

INFLUENCE OF TEMPERATURE ON MODE I FRACTURE TOUGHNESS OF A DUCTILE ADHESIVE.

Lukáš HORÁK¹, Jan KRYSTEK²

¹ [0009-0003-8975-2865](https://orcid.org/0009-0003-8975-2865), Faculty of Applied Sciences – University of West Bohemia, Technická 8, Pilsen, Czech Republic, E-mail: horakl@kme.zcu.cz;

² [0000-0002-2805-1542](https://orcid.org/0000-0002-2805-1542), Faculty of Applied Sciences – University of West Bohemia, Technická 8, Pilsen, Czech Republic, E-mail: krystek@kme.zcu.cz;

1. Introduction

The main goal of this study is to quantify the effect of temperature on Mode I fracture toughness for a ductile adhesive. Later, this set of material parameters was used to simulate a Double Cantilever Beam (DCB) sample with various shapes of Traction-separation models to better capture the gradual failure of the adhesive under different thermal operating conditions.

2. Experiments

To describe the adhesive in its simplest form, we need a set of material parameters which are summarized in Table 1; the methodology for obtaining all of the specified parameters was in detail described in [1]. These are applicable primarily for brittle adhesive.

Table 1. Parameters for complex numerical simulation of brittle adhesive

Zone name	Parameter	Symbol	Unit
Elastic	Young's modulus	E	[Pa]
	Poisson's ratio	ν	[-]
	Shear modulus	G	[Pa]
Initiation of Fracture	Tensile failure strength	σ_f^T	[Pa]
	Shear failure strength	τ_f	[Pa]
	Tensile failure strain	ε_f^T	[-]
Crack Propagation	Strain energy release rate for mod I	G_I	[Jm ⁻²]
	Strain energy release rate for mod II	G_{II}	[Jm ⁻²]

To simplify the process in modelling same material parameters were used for modelling ductile adhesive with expansion to different traction-

separation shapes. Araldite 2015 A+B was chosen as a representative of a ductile adhesive.

Mode I fracture toughness was evaluated by performing a DCB test which was chosen as a most suitable method [2]. Experiments were performed on a universal testing machine with a thermal chamber.

Temperature dependence of adhesive was evaluated in a range of negative and positive values of Celsius, with the highest one exceeding the glass transition temperature value. Before the experiment itself the samples were tempered to the desired temperature.

2.1 DCB Sample

During the loading of the DCB specimen with a constant crosshead rate, the crack growth has to be stable and no excessive bending with large plastic deformation should occur in adherends. For this purpose, numerical simulation of DCB samples were first analyzed to better choose the adherends material and thickness based on the approximation of material parameters in literature [3]. Based on that and by experimental verification samples were fabricated from two prismatic aluminums (EN AW-2024 T3) strips with thickness of 1.6 mm.

The constant thickness and alignment of the whole sample were ensured by use of several molds designed for this purpose. Geometry and dimensions of the sample are apparent from Fig. 1 where all of the values presented are in mm.

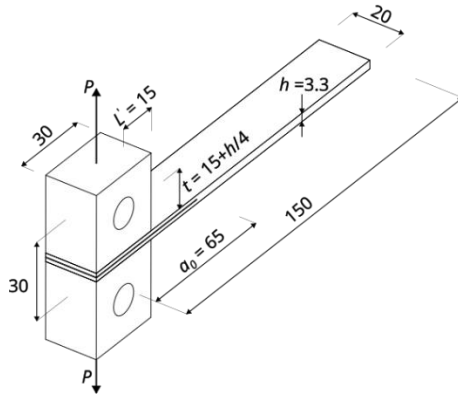

Fig. 1. Geometry of DCB sample [1].

2.2 Evaluation

For the evaluation of the strain energy release rate for mod I, the Modified Beam Theory reduction method was used as

$$G_I = \frac{3P\delta}{2B(a+|\Delta|)}. \quad (1)$$

Correction factor N was used on the compliance C and on the strain energy release rate G_I to capture the stiffening of the adherends due to use of block for load distribution. The crack length a was visually observed and measured from synchronized photographs taken during measurement. Force P was measured with a load cell and load point displacement δ with extensometer.

3. Simulations

All of the mechanical data of the adhesive was used for numerical simulations of DCB samples. These were performed with a study of traction-separation shapes. Some basic shapes were tested, as seen in Fig. 2, including bilinear, trilinear, parabolic, and exponential shapes as suggested in [4].

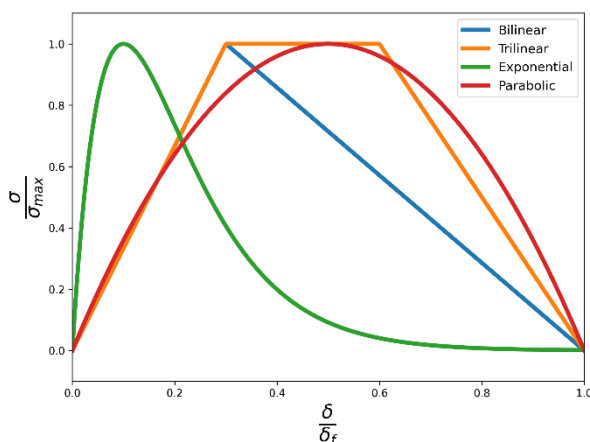

Fig. 2. Different forms of the traction-separation law.

For the purpose of easily defining the Traction-separation shape and future extension of the model the user material definition VUMAT was defined in finite element analysis software Abaqus.

4. Conclusions

In this work, the influence of temperature on Mode I fracture toughness of a ductile adhesive was studied, with a study of different traction-separation shapes to better capture adhesive degradation.

Acknowledgments

Work was supported by the project SGS-2025-015 of the University of West Bohemia.

References

- [1] Horák, L., Krystek, J. Methodology and Determination of Parameters for Modeling Brittle Adhesive. In *Proceedings of the EAN 2024 - 62nd International Conference on Experimental Stress Analysis*, Boží Dar, 4-6 June, 2024;
- [2] Banea, M.D., da Silva, L.F.M. Adhesively bonded joints in composite materials: An overview. In *Proceedings of the Institution of Mechanical Engineers, Part L: Journal of Materials: Design and Applications*, 2016, 223(1), pp. 1–18;
- [3] Campilho, R.D.S.G., Pinto, A.M.G., Banea, M.D., Silva, R.F., da Silva, L.F.M. Strength Improvement of Adhesively-Bonded Joints Using a Reverse-Bent Geometry. *Journal of Adhesion Science and Technology*, 2011, 25(18), pp. 2351–2368;
- [4] Dogan, F., Hadavinia, H., Donchev, T., Bhonge, P., Delamination of impacted composite structures by cohesive zone interface elements and tiebreak contact. *Central European Journal of Engineering*, 2012, 2(4), pp. 612–626;